

LC-R122R2PU

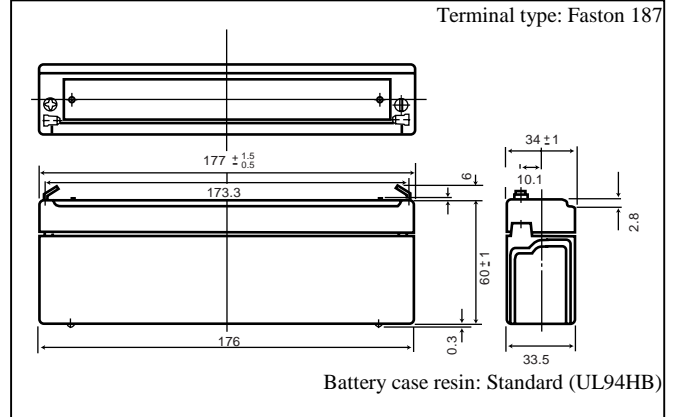

For main and standby power supplies.
Expected trickle life: 3-5 years at 25°C, 5 years at 20°C.

Dimensions (mm)



Specifications

Nominal voltage		12V
Rated capacity (20 hour rate)		2.2Ah
Dimensions	Length	177 mm
	Width	34 mm
	Height	60 mm
	Total Height	66 mm
Approx. mass		0.8 kg
Country of origin		Japan

Discharge characteristics (25°C) (note)

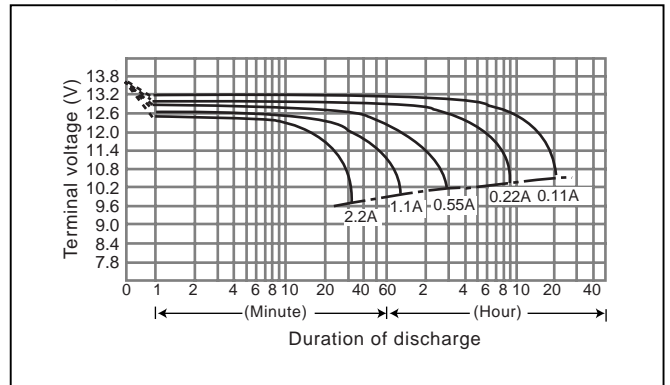

Characteristics

Capacity (note) (25°C)	20 hour rate (110mA)	2.2Ah	
	10 hour rate (200mA)	2.0Ah	
Internal resistance	5 hour rate (360mA)	1.8Ah	
	1 hour rate (1300mA)	1.3Ah	
	1.5 hour rate discharge Cut-off voltage 10.5 V	0.95A	
Temperature dependency of capacity (20 hour rate)	Fully charged battery (25°C)	Approx. 70mΩ	
	40°C	102 %	
	25°C	100 %	
	0°C	85 %	
Self discharge (25°C)	-15°C	65 %	
	Residual capacity after standing 3 months	91%	
	Residual capacity after standing 6 months	82%	
Charge Method (Constant Voltage)	Residual capacity after standing 12 months	64%	
	Cycle use (Repeating use)	Initial current	0.88 A or smaller
		Control voltage	Constant voltage; 14.5 to 14.9 V (per 12V cell 25°C)
	Trickle use	Control voltage	13.6 to 13.8 V (per 12V cell 25°C)

Duration of discharge vs. Discharge current (note)

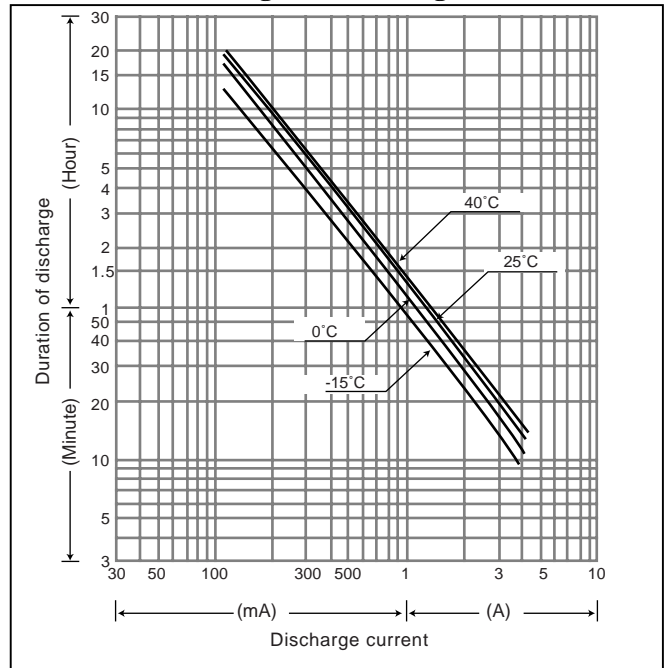

(Note) The above characteristics data are average values obtained within three charge/discharge Cycles not the minimum values.