

**LC-XA12100P**

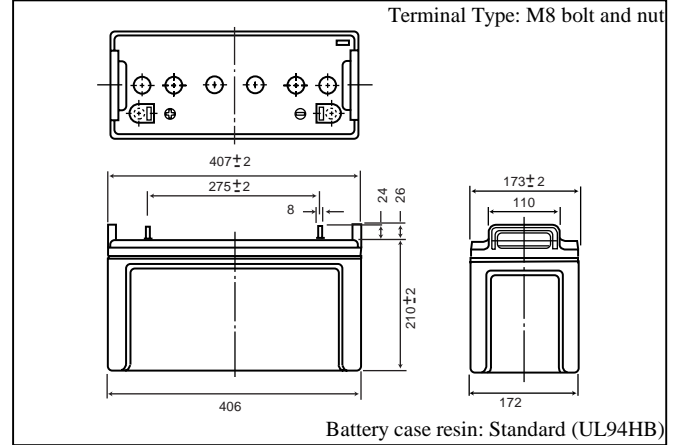

For standby power supplies.  
Expected trickle life: 6 years at 25°C, 10 years at 20°C.

**Dimensions (mm)**



**Specifications**

Nominal voltage		12V
Rated capacity (20 hour rate)		100Ah
Dimensions	Length	407 mm
	Width	173 mm
	Height	210 mm
	Total Height	236 mm
Approx. mass		33.0 kg
Country of origin		Republic of China

**Discharge characteristics (25°C) <sup>(note)</sup>**

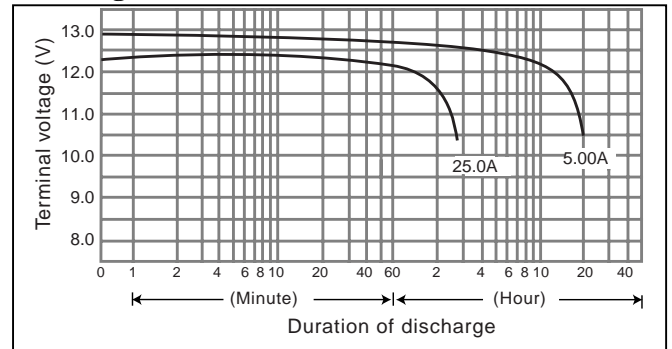

**Duration of discharge vs. Discharge current <sup>(note)</sup>**

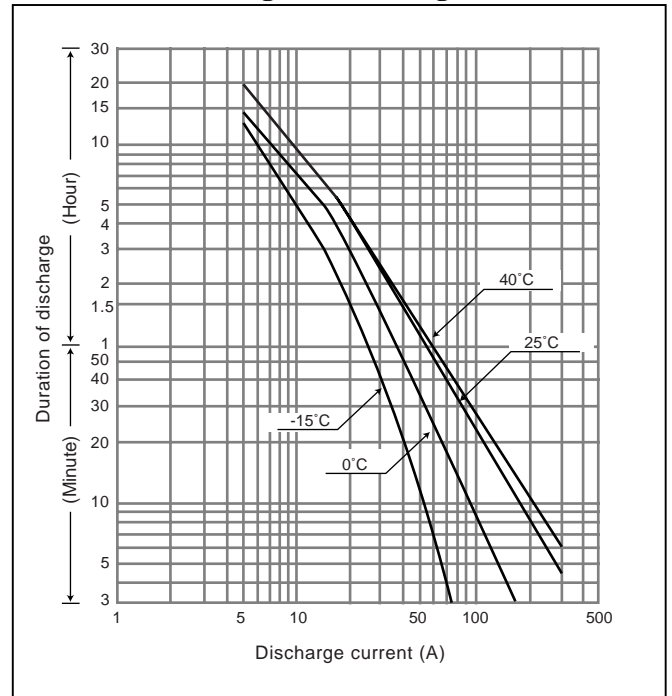

**Characteristics**

Capacity <sup>(note)</sup> (25°C)	20 hour rate (5.0A)	100.0Ah	
	10 hour rate (9.8A)	98.0Ah	
	5 hour rate (18.0A)	90.0Ah	
	1 hour rate (55.0A)	55.0Ah	
	1.5 hour rate discharge	40A	
	Cut-off voltage 10.5 V		
Internal resistance	Fully charged battery (25°C)	Approx. 4.5mΩ	
Temperature dependency of capacity (20 hour rate)	40°C	102 %	
	25°C	100 %	
	0°C	85 %	
	-15°C	65 %	
Self discharge (25°C)	Residual capacity after standing 3 months	91%	
	Residual capacity after standing 6 months	82%	
	Residual capacity after standing 12 months	64%	
Charge Method (Constant Voltage)	Trickle use	Control voltage	13.6 to 13.8 V (per 12V cell 25°C)

(Note) The above characteristics data are average values obtained within three charge/discharge Cycles not the minimum values.